

## Energy Saving LT Line-Up System for wall freezing cabinets with Aluminium Framed Doors

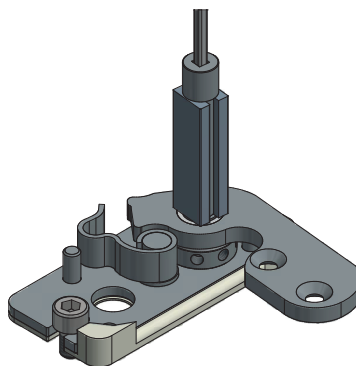

**ALL DIMENSIONS AVAILABLE ON DEMAND**

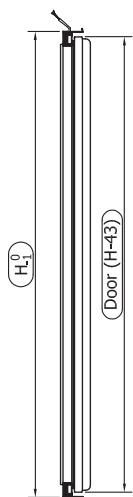
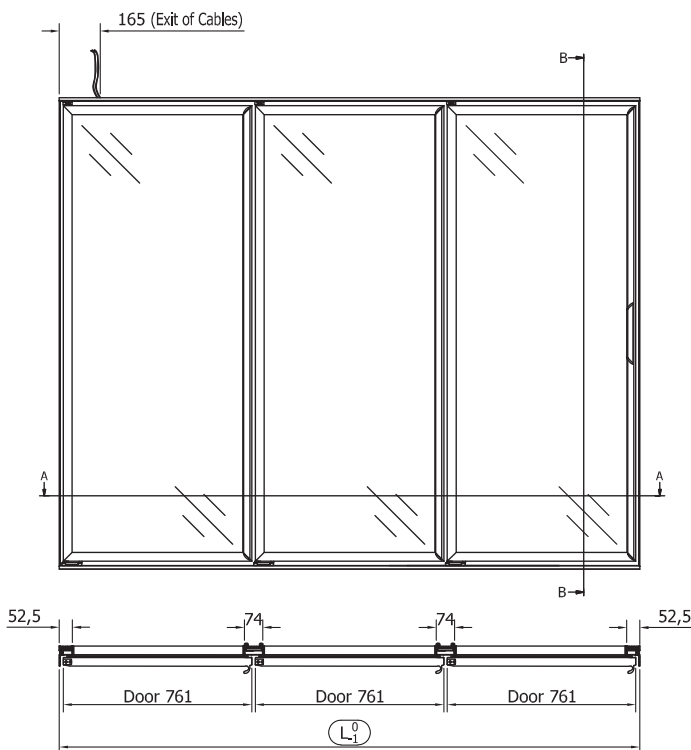
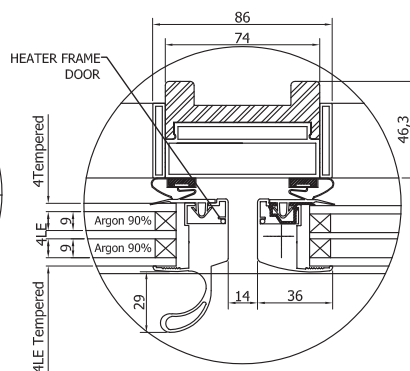
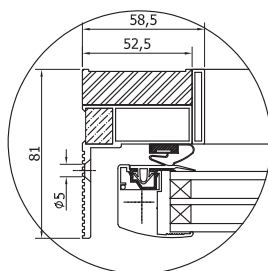
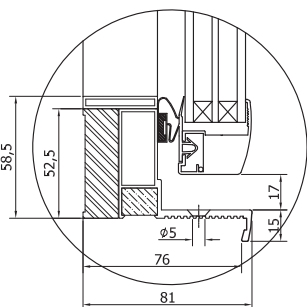
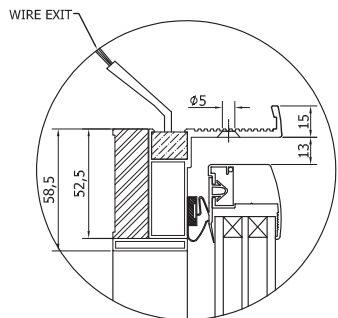

### 0 ENERGY ALUMINIUM FRAMED GLASS DOOR

Exclusive design and full height comfortable grip handle

Left to right hand and vice versa reversible door

Swing door made of triple glass with security exterior layers according to UNI 12150 standard

"0 Energy" insulated glass unit complying with UNI 23953 Class 3 requirements

Anti-fog treatment on the inner glass layer

"0 Energy" PVC and Aluminium combined frame

Adjustable self-closing action by torsion bar

Manual open wide door retainer

### LOW ENERGY MASTER FRAME

50% heating power reduction face to the standard configuration

Product complying with UNI 23953 Class 3 requirements

Silver satin aluminium and Ral 7035 special Pvc covers

Any frame is adapted to receive Aluminium Framed or Full Glass Doors by TGD

Available configurations: 1, 2, 3, 4 and 5 openings

Led on board or led pre-wired configuration available

## Energy Saving LT Line-Up System for wall freezing cabinets with Full Glass Doors

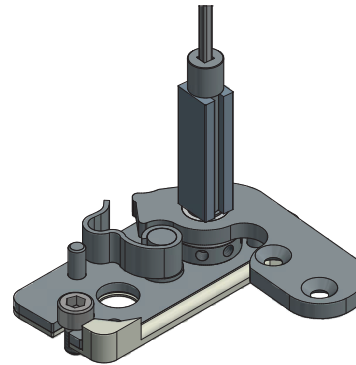
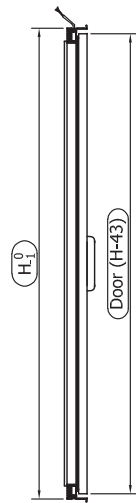
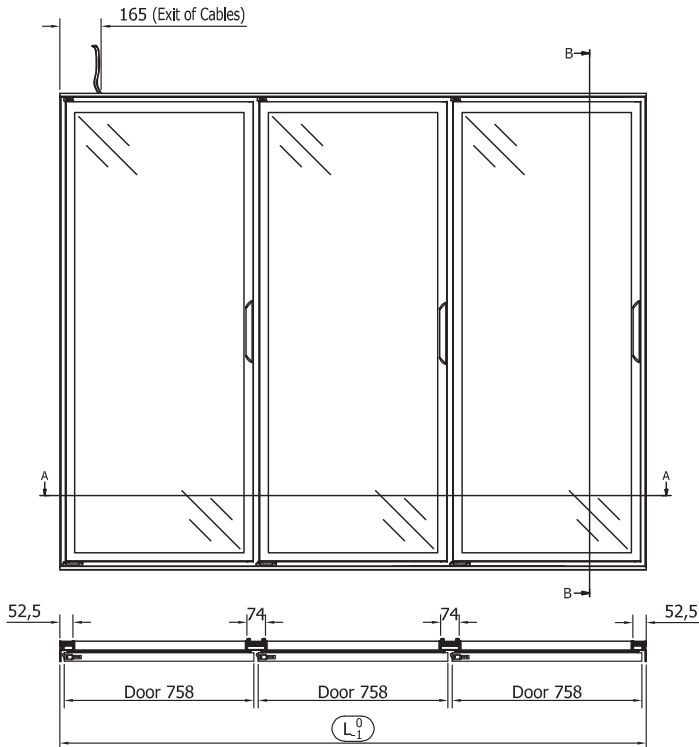

**ALL DIMENSIONS AVAILABLE ON DEMAND**

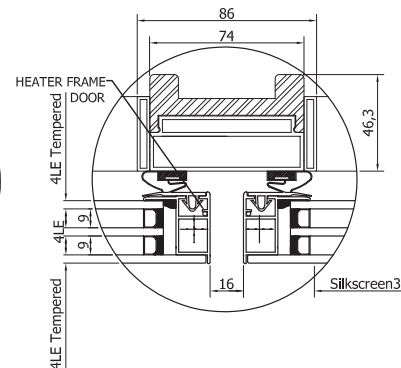
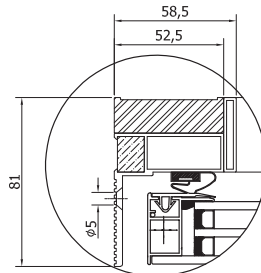
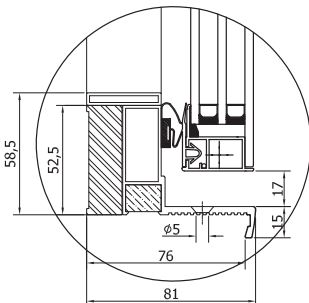
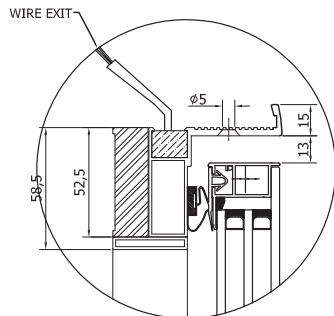

### 0 ENERGY FULL GLASS DOOR

Full Glass door with customizable exterior Ral 9005 silk screen (other colours available on demand)

High fashion Italian design with full height or short comfortable grip handle

Left to right hand reversible door

Swing door made of triple glazing glass with security exterior layers according to UNI 12150 standard

"0 Energy" insulated glass unit complying with UNI 23953 Class 3 requirements

Anti-fog treatment on the inner glass layer

"0 Energy" PVC and Aluminium hidden combined frame

Adjustable self-closing action by torsion bar

Manual open wide retainer

### STANDARD HEATING MASTER FRAME

50% heating power reduction face to the standard configuration

Product complying with UNI 23953 Class 3 requirements

Silver satin aluminium and Ral 7035 special Pvc covers

Any frame is adapted to receive Aluminium Framed or Full Glass Doors by TGD

Available configurations: 1, 2, 3, 4 and 5 openings

Led on board or led pre-wired configuration available